

GEBRAUCHSANLEITUNG

D

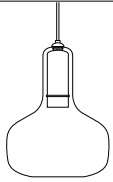

BOOH 250 GU10 DLR

ART.-NO. 860682
 860683

TECHNISCHE DATEN

Spannung: 230VAC
 Leistung: 9W
 Fassung: GU10

Schutzklasse:



Dimmbar:
bruck.de/de/faq/bruck



ALLGEMEINE SICHERHEITSHINWEISE



1. Montage und Inbetriebnahme der Produkte nur durch autorisiertes Fachpersonal unter Berücksichtigung dieser Montageanleitung, Sicherheitshinweisen und aller für den Anwendungsbereich geltenden Normen und Vorschriften sind einzuhalten!
2. Bei allen durchzuführenden Arbeiten an den Produkten (Montage, Wartung, Reinigung) Spannungsversorgung abschalten.
3. Die Produkte sind nur für IP 20 Bereiche zugelassen.
4. Den angegebenen Mindestabstand der Lichtquelle zur beleuchtenden Fläche beachten*
5. Wir behalten uns vor, jederzeit Änderungen an den Produkten vorzunehmen! Aktuelle Daten finden sie jederzeit unter www.bruck.de.
6. Bei eigenmächtigen Veränderungen oder unsachgemäßer Benutzung erlischt jeglicher Anspruch auf Gewährleistung.



LIEFERUMFANG
 I LEUCHE OHNE LEUCHTMITTEL



MONTAGE: FALSCH

MOUNTING: WRONG
 MONTAGE: INCORRECT
 MONTAJE: INCORRECTO
 MONTAGGIO: SBAGLIATO

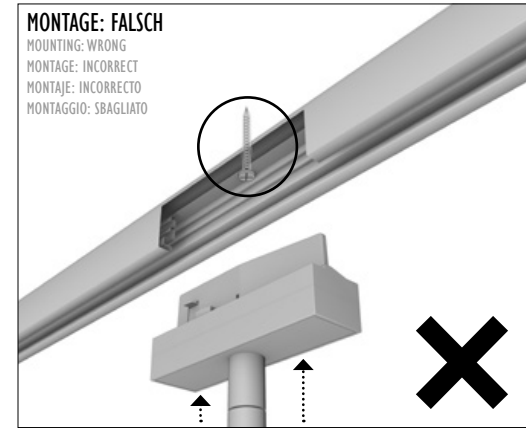

MONTAGE: RICHTIG

MOUNTING: CORRECT
 MONTAGE : CORRECT
 MONTAJE: CORRECTO
 MONTAGGIO: CORRETTO

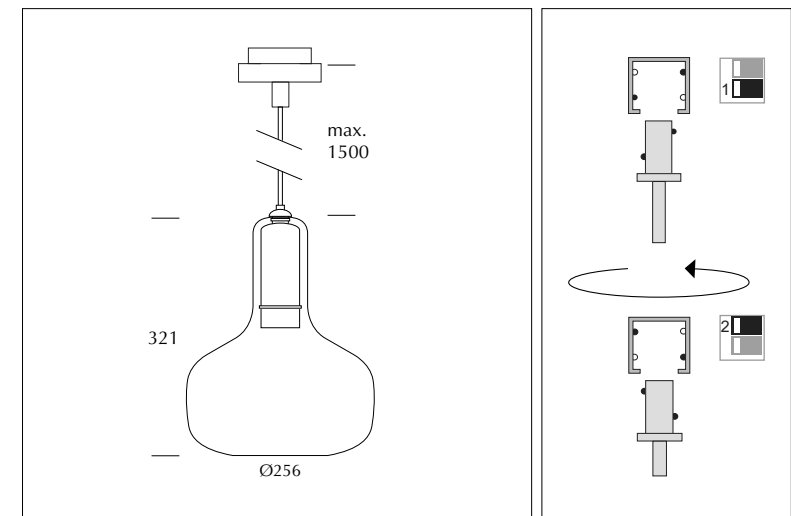
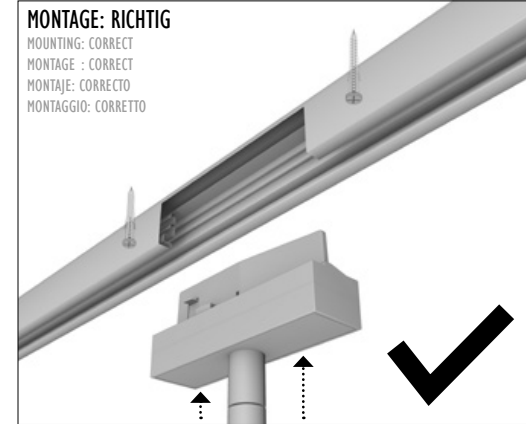

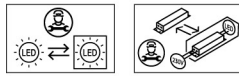

INSTRUCTION MANUAL

GB

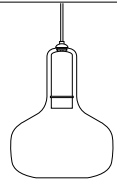

BOOH 250 GU10 DLR

ART.-NO. 860682
860683

TECHNICAL DATA

Voltage: 230VAC
 Wattage: 9W
 Lampholder: GU10

Protection class:



Dimmable:
bruck.co.uk/en/faq/dimmer-recommendation/



GENERAL REMARKS ON SAFETY



1. Installation and commissioning of the products only by authorised qualified personnel, taking into account these installation instructions, safety instructions and all standards and regulations applicable to the area of application must be observed!
2. For all work to be carried out on the products (assembly, maintenance, repair, cleaning, etc.) switch off the power supply.
3. The products are only approved for IP 20 areas.
4. Observe the specified minimum distance of the light source from the illuminating surface*
5. We reserve the right to make changes to the products at any time! Current data can be found at www.bruck.de.
6. With arbitrary changes or improper use any warranty claim expires.



DELIVERY SCOPE:
 1 LUMINAIRE WITHOUT LAMP



MODE D'EMPLOI

F

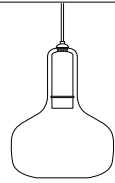

BOOH 250 GU10 DLR

REF. 860682
860683

CARACTERISTIQUES TECHNIQUES

Voltage: 230VAC
 Puissance: 9W
 Douille: GU10

Classe de protection:



Gradable:
bruckclairage.fr/fr/faq/recommandation-du-gradateur/



CONSIGNES DE SECURITE GENERALES



1. Le montage et la mise en service des produits ne doivent être effectués que par un personnel qualifié et autorisé, en tenant compte des présentes instructions de montage, des consignes de sécurité et de toutes les normes et prescriptions en vigueur pour le domaine d'application.
2. Pour tous les travaux à effectuer sur les produits (montage, entretien, réparation, nettoyage, etc.) il faut couper l'alimentation électrique.
3. Les produits ne sont homologués que pour les zones IP 20.
4. Respecter la distance minimale indiquée entre la source lumineuse et la surface à éclairer*
5. Nous nous réservons le droit d'apporter des modifications aux produits à tout moment ! Les données actuelles peuvent être consultées à tout moment sur www.bruck.de.
6. En cas de modifications arbitraires ou d'utilisation incorrecte, la garantie expire.



VOLUME DE LIVRAISON:
 1 LUMINAIRE SANS LAMPE



INSTRUCCIONES DE EMPLEO

E

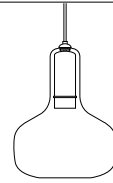

BOOH 250 GU10 DLR

REF. 860682
860683

DATOS TECNICOS

Voltaje: 230VAC
 Potencia: 9W
 Portalámparas: GU10

Clase de protección:



Regulable:
bruck.com.es/es/faq/recomendacion-de-atenuacion/



INDICACIONES GENERALES DE SEGURIDAD



1. La instalación y puesta en marcha de los productos sólo debe ser realizada por personal cualificado autorizado, teniendo en cuenta estas instrucciones de instalación, las instrucciones de seguridad y todas las normas y reglamentos aplicables al área de aplicación.
2. Para todos los trabajos a realizar en los productos (montaje, mantenimiento, reparación, limpieza, etc.) hay que desconectar la alimentación eléctrica.
3. Los productos sólo están aprobados para áreas IP 20.
4. Respete la distancia mínima especificada de la fuente luminosa a la superficie iluminante*
5. Nos reservamos el derecho de hacer cambios en los productos en cualquier momento! Los datos actuales se pueden encontrar en www.bruck.de.
6. Con cambios arbitrarios o uso indebido caduca cualquier reclamo de garantía.



VOLUMEN DE ENTREGA:
 1 LUMINAIRE SENZA LAMPADA



ISTRUZIONI PER L'USO

I

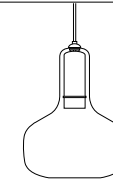

BOOH 250 GU10 DLR

COD. 860682
860683

DATI TECNICI

Tensione: 230VAC
 Wattaggio: 9W
 Apparecchio d'illuminazione: GU10

Tipo di protezione:



Dimmerabile:
bruck.co.it/it/faq/raccomandazione-varialuce/



AVVERTENZE GENERALI PER LA SICUREZZA



1. L'installazione e la messa in funzione dei prodotti devono essere eseguite esclusivamente da personale qualificato e autorizzato, tenendo conto delle presenti istruzioni per l'installazione, delle norme di sicurezza e di tutte le norme e i regolamenti applicabili al settore di applicazione!
2. Per tutti i lavori da eseguire sui prodotti (montaggio, manutenzione, riparazione, pulizia ecc.) spegnere l'alimentazione elettrica.
3. I prodotti sono approvati solo per ambienti IP 20.
4. Rispettare la distanza minima specificata della sorgente luminosa dalla superficie illuminante*
5. Ci riserviamo il diritto di apportare modifiche ai prodotti in qualsiasi momento! I dati attuali possono essere trovati in qualsiasi momento all'indirizzo www.bruck.de.
6. In caso di modifiche non autorizzate o di uso improprio, tutti i diritti di garanzia scadano.



VOLUME DELLA FORNITURA:
 1 LUMINAIRE SIN LÁMPARA



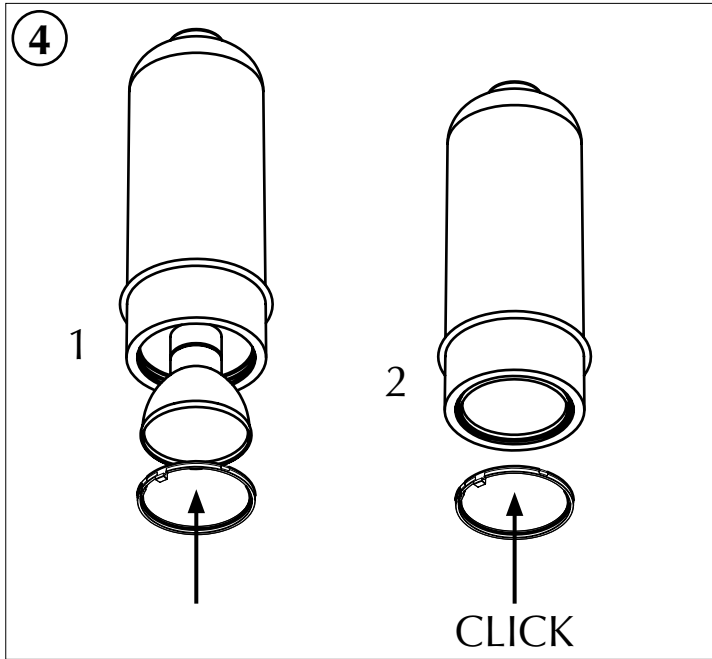
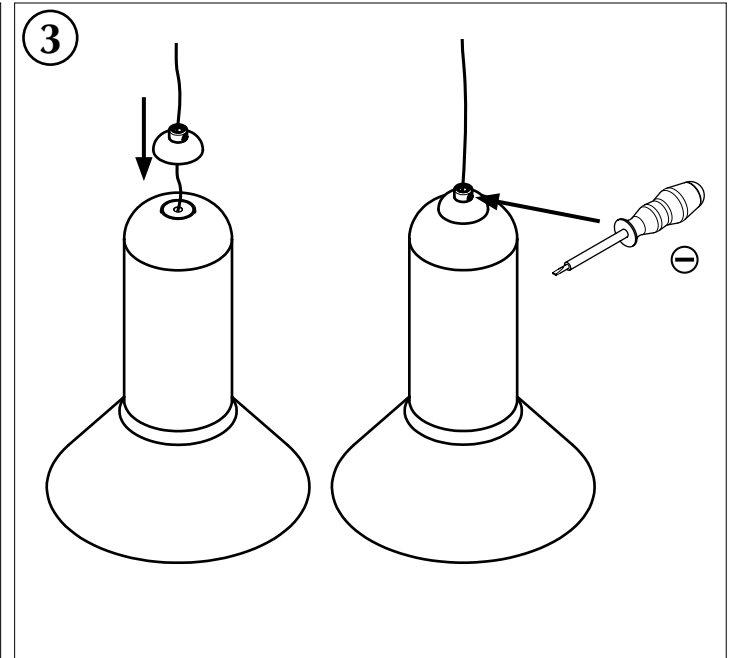
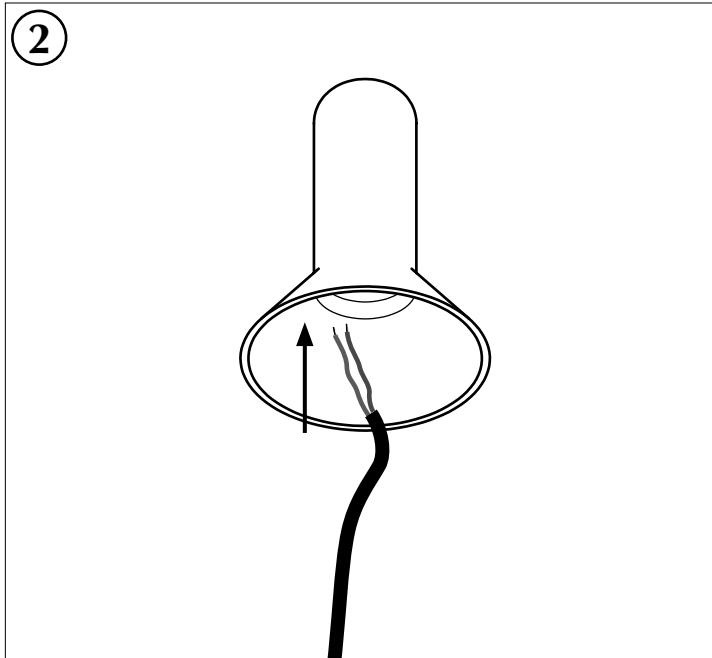
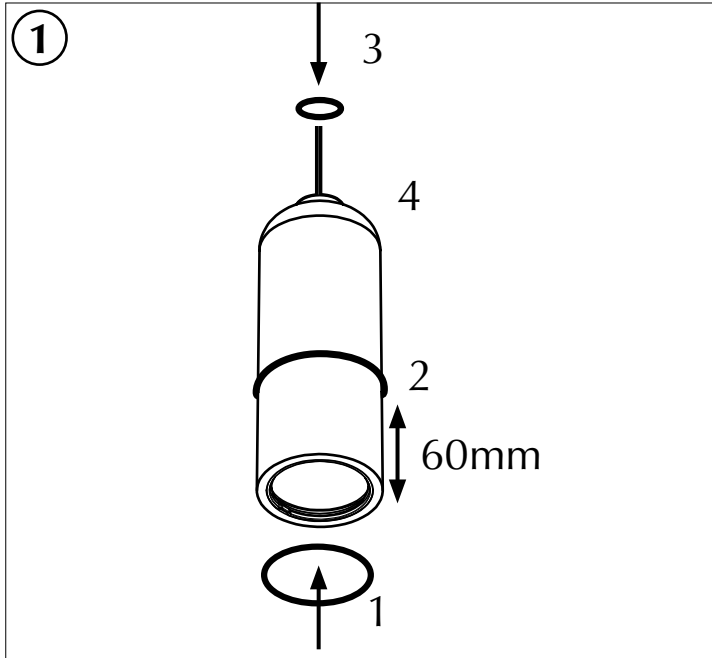

Leuchtmittel ist nicht im Lieferumfang enthalten.
 Bulb is not included in the scope of delivery.
 L'ampoule n'est pas comprise dans la livraison.
 La bombilla no está incluida en el suministro.
 La lampadina non è inclusa nella fornitura.

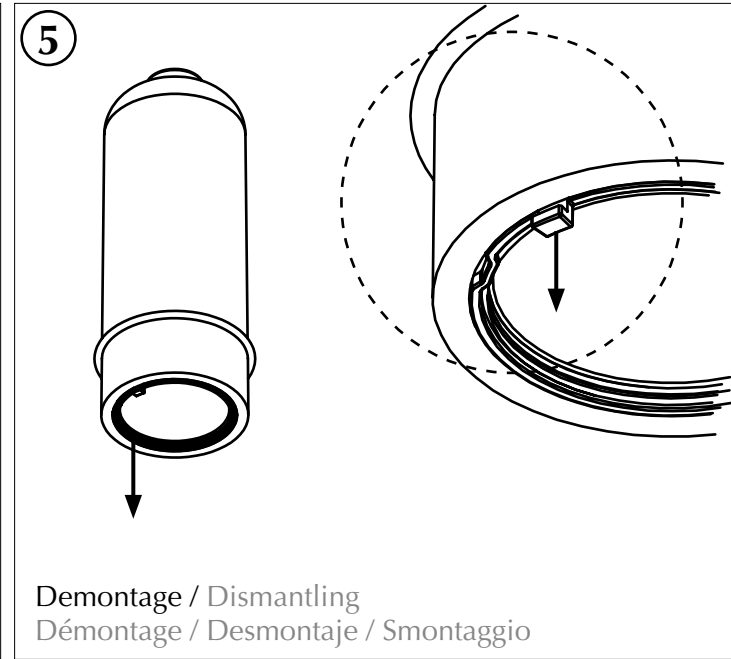

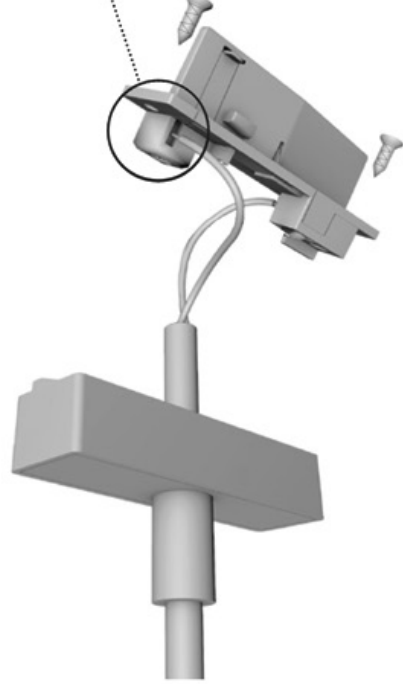
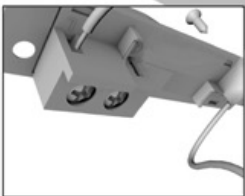
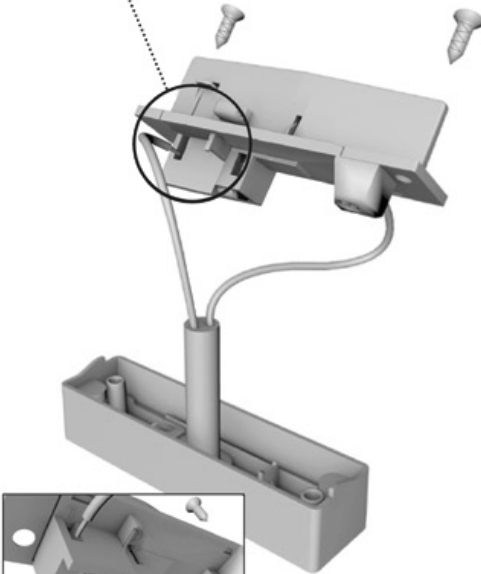
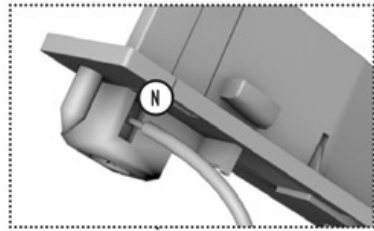
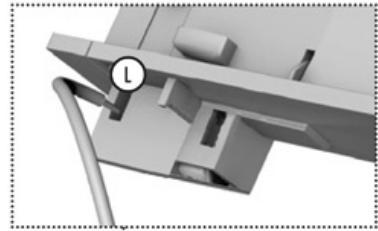

1.

Kabel muss vor der Montage durch das Mittelloch des Adapters geführt werden.

Before mounting, the cable must be routed through the middle hole of the adapter.

Avant le montage, le câble doit être passé par le trou au milieu du adaptateurs.

Antes del montaje el cable tiene que ser pasado por el agujero mediano del adaptadores.

Prima del montaggio, il cavo deve essere instradato attraverso il foro centrale del baldacchino.

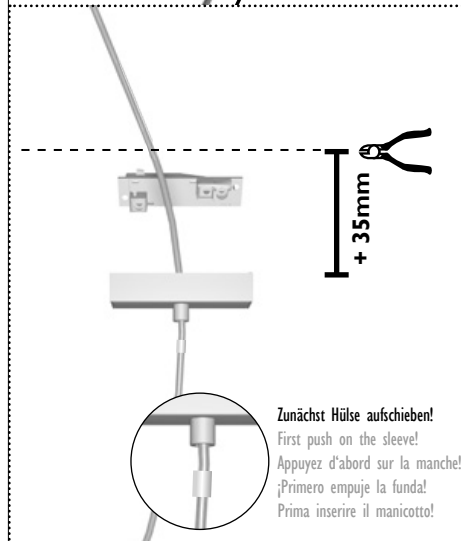
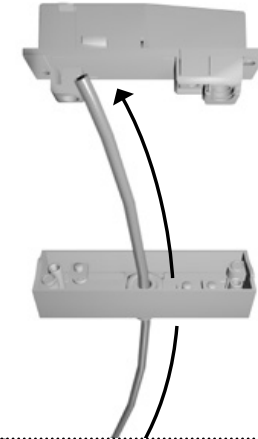

Zunächst Hülse aufschieben!
 First push on the sleeve!
 Appuyez d'abord sur la manche!
 ¡Primer empuje la funda!
 Prima inserire il manicotto!

+ 35mm

Gewünschte Länge / Desired length / Longueur désirée / Lunghezza desiderata

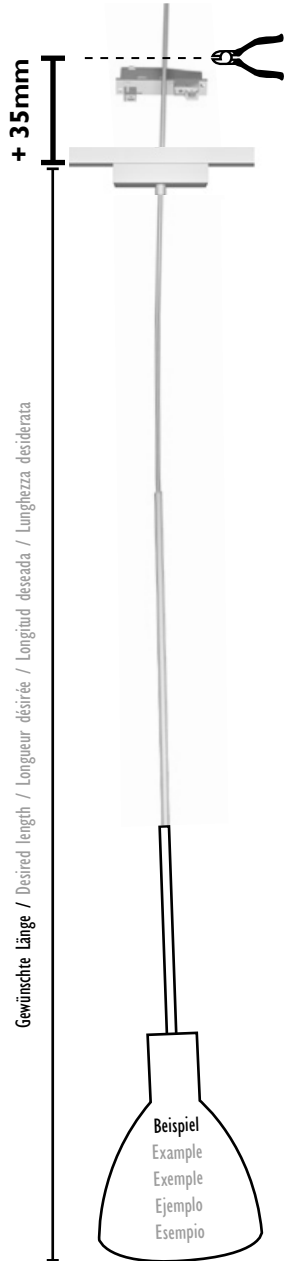

Beispiel
 Example
 Exemple
 Ejemplo
 Esempio

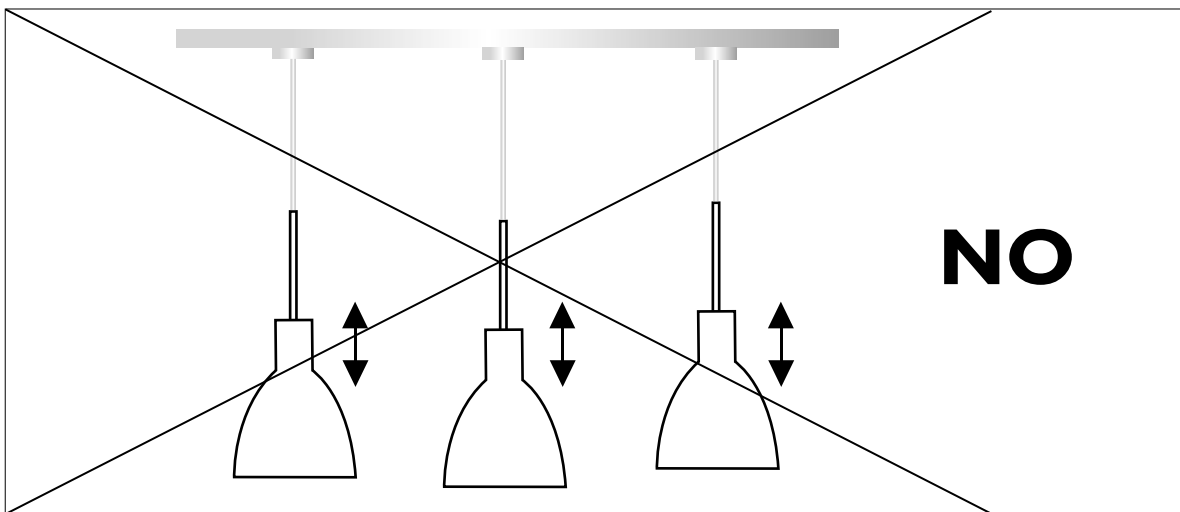
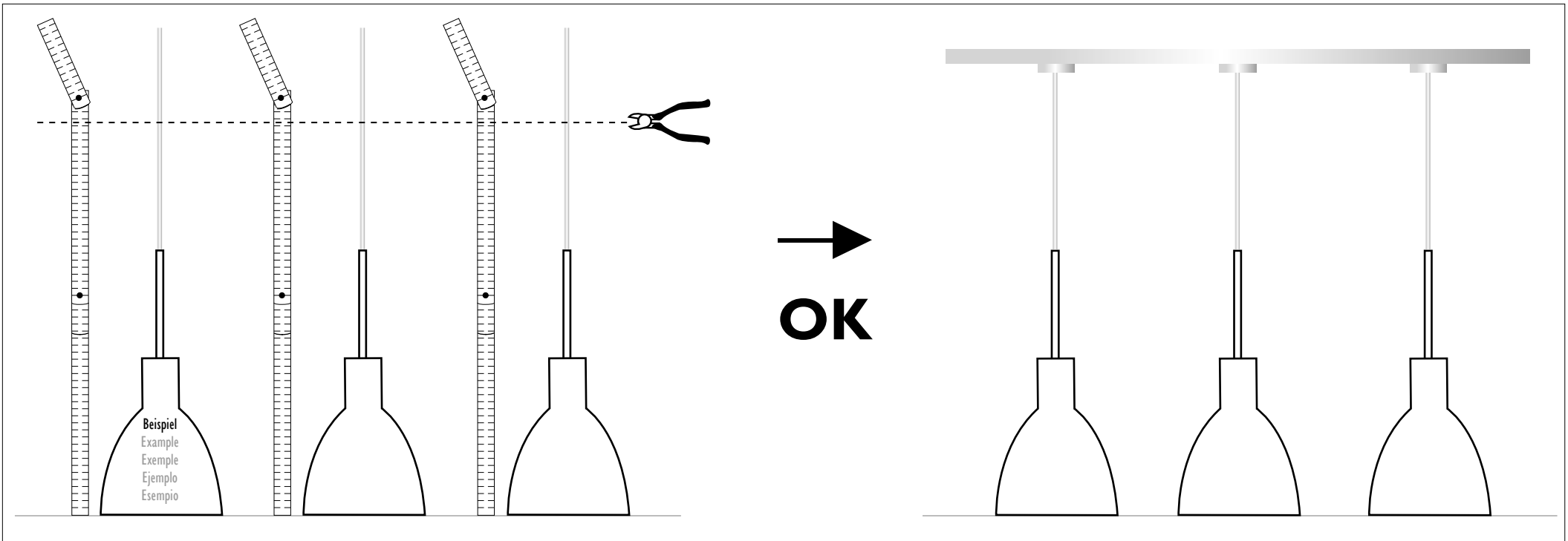

ACHTUNG! ATTENTION! ATTENTION! ¡ATENCIÓN! ATENZIONE!

Alle Kabel auf gleiche Länge kürzen.

Danach ist eine Korrektur der Höhe nicht mehr möglich.

Shorten all cables to the same length.

Height cannot be adjusted afterwards.

Raccourcissez tous les câbles à la même longueur.

Après cela, une correction de la hauteur n'est plus possible.

Accorte todos los cables a la misma longitud.

A partir de entonces, ya no es posible corregir la altura.

Accorciare tutti i cavi alla stessa lunghezza.

Dopo non è più possibile correggere l'altezza.

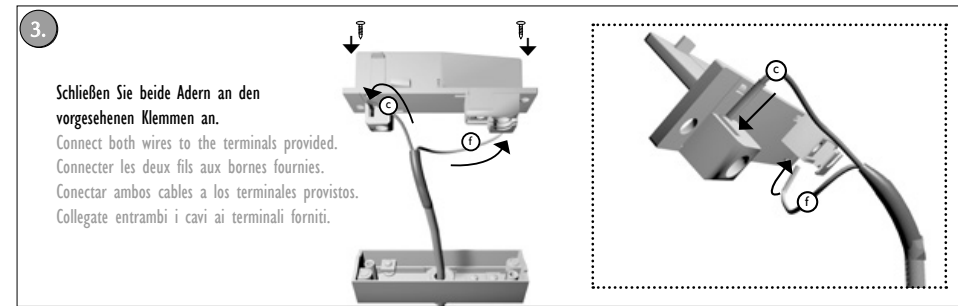
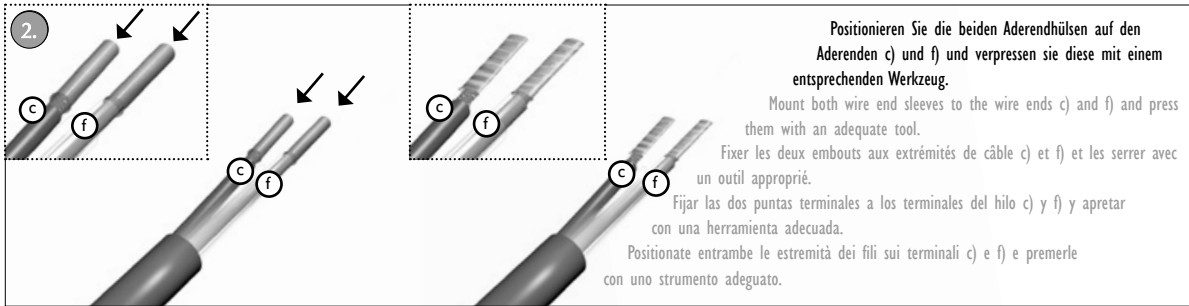

ADAPTER MONTIEREN / ASSEMBLING THE ADAPTER THE ADAPTER / MONTAGE DE L'ADAPTEUR / MONTAJE DEL ADAPTADOR / MONTARE L'ADATTATORE

ADAPTER ABMONTIEREN / DISASSEMBLING THE ADAPTER / DEMONTAGE DE L'ADAPTEUR / DESMONTAJE DEL ADAPTADOR / RIMUOVERE L'ADATTATORE

