

## DUOLARE HV-SCHIENENSYSTEM D

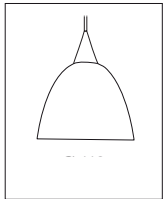

### SILVA / DOWN 160 DLR

ART.-NO.	860 367	860 373
	860 369	860 374
	860 370	860 375
	860 371	860 368
	860 372	

## DUOLARE HV TRACK SYSTEM GB

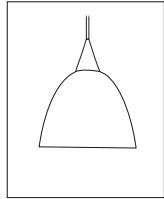

### SILVA / DOWN 160 DLR

ART.-NO.	860 367	860 373
	860 369	860 374
	860 370	860 375
	860 371	860 368
	860 372	

## DUOLARE SYSTÈME DE RAIL HT F

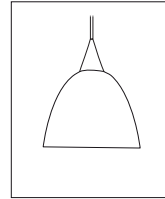

### SILVA / DOWN 160 DLR

ART.-NO.	860 367	860 373
	860 369	860 374
	860 370	860 375
	860 371	860 368
	860 372	

## GEBRAUCHSANLEITUNG D

### TECHNISCHE DATEN

Material :	Messing, Aluminium
Oberfläche :	matthrom
Spannung :	230 / 240V
Belastung :	max. 60 W
Fassung f. Sockel :	G 9
Leuchtmittel :	QT 14

Schutzklasse:



## USER MANUAL GB

### TECHNICAL DATA

Materials:	brass, aluminium
Surface:	matchrome
Voltage:	230 / 240 V
Load:	max. 60 W
Lampholder f. Socket:	G 9
Lamp:	QT 14

Protection class :



## MODE D'EMPLOI F

### CARACTERISTIQUES TECHNIQUES

Matériaux:	Laiton, Aluminium
Surface:	chrome mat
Voltage:	230 / 240 V
Wattage:	max. 60 W
Douille:	G 9
Lampe:	Q 14

classe de protection:

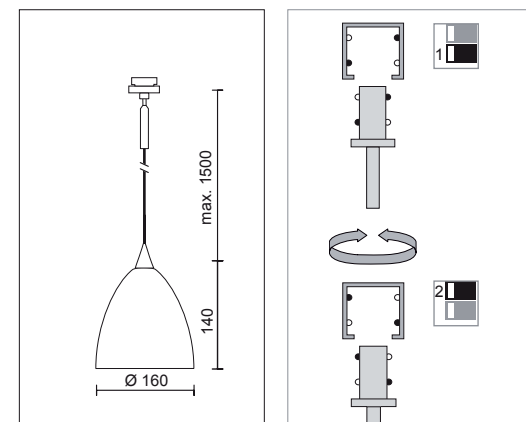
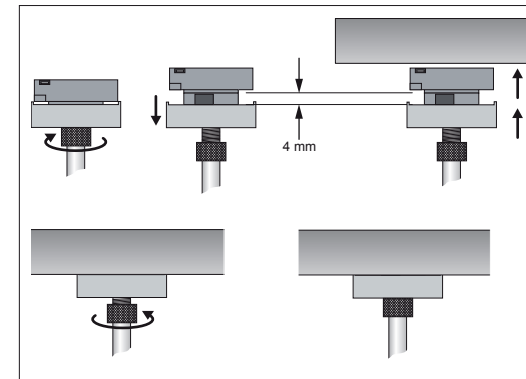
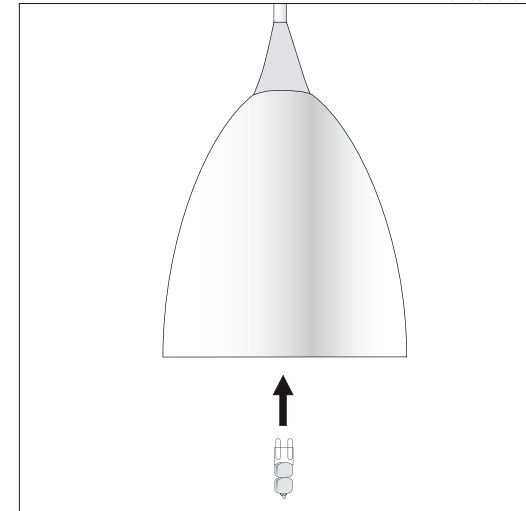

### ALLGEMEINE SICHERHEITSHINWEISE

- Bei allen an der Leuchte durchzuführenden Arbeiten (Wartung, Reinigung) Leuchte spannungsfrei schalten!!
- Leuchte ist nicht für Feuchträume geeignet.
- Vorsicht! Leuchte und Leuchtmittel werden in Betrieb heiß
- Den angegebenen Mindestabstand der Leuchtmittel zu brennbaren Gegenständen beachten! (siehe Leuchte )
- Achtung: Zur Verminderung der Gefahr von Überhitzung und Feuer keine Leiter überbrücken.
- Kein Garantieanspruch bei eigenmächtigen Veränderungen und oder unsachgemäßer Benutzung!

### LIEFERUMFANG

1 Leuchte komplett ohne Leuchtmittel



### GENERAL REMARKS ON SAFETY

- For all work to be performed on the lamp (maintenance, cleaning): Switch off power to the lamp!!
- Lamp not suitable for installation in wet rooms.
- Take care! Lamp and illuminant become hot during operation.
- Observe the stated minimum distance of the illuminants to flammable objects! (see lamp )
- Attention: In order to minimise the risk of overheating or fire do not bypass any conductors.
- No warranty claim in case of unauthorized modifications and / or improper use!

### DELIVERY SCOPE

1 light complete without lamp



### CONSIGNES DE SECURITE GENERALES

- Avant d'effectuer tout travail sur le luminaire (entretien et nettoyage) mettre le luminaire hors tension
- N'est pas approprié à être installé dans des pièces humides
- Attention ! Les luminaires et les lampes sont brûlantes lors de leur utilisation.
- Veiller à respecter l'intervalle minimum indiqué des lampes par rapport à des objets inflammables! (voir luminaires )
- Attention: afin de minimiser les risques de surchauffe et d'incendie, ne pas court-circuiter les conducteurs.
- Nous ne donnons aucune garantie lors de modifications effectuées sur le matériel ou lors d'une utilisation inadéquate

### VOLUME DE LIVRAISON

1 luminaire complet sans lampe



## DUOLARE SISTEMA DE RIELES AV

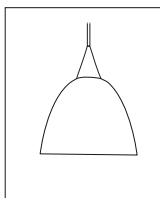

### SILVA / DOWN 160 DLR

ART.-NO.	860 367	860 373
	860 369	860 374
	860 370	860 375
	860 371	860 368
	860 372	

## INSTRUCCIONES DE EMPLEO

### DATOS TECNICOS

Materiales:	latón, aluminio
Superficie:	romo mate
Voltaje:	230 / 240 V
Carga:	max. 60 W
Portalámpara:	G 9
Lámpara:	QT 14

Clase de protección: 

### INDICACIONES GENERALES DE SEGURIDAD

- ¡En todos los trabajos a llevar a cabo en las lámparas (trabajos de mantenimiento y limpieza) han de mantenerse las lámparas libre de tensión!
- El sistema no es apropiado para la instalación en locales húmedos.
- ¡Cuidado! Las lámparas y las bombillas o reflectores se calientan durante el funcionamiento.
- ¡Ha de observarse la distancia mínima indicada de las bombillas o reflectores respecto de los objetos combustibles! (véase la lámpara ).
- Atención: no puentee ningún conductor eléctrico para así disminuir el riesgo de sobrecalentamiento e incendio.
- ¡Se pierden las reivindicaciones de garantía al llevar modificaciones a cabo por propia cuenta y / o empleo incorrecto!

**VOLUMEN DE SUMINISTRO**  
1 lámpara completo sin lámpara.



## DUOLARE SISTEMA A BINARIO AV

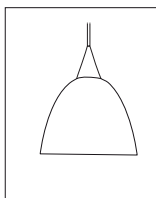

### SILVA / DOWN 160 DLR

ART.-NO.	860 367	860 373
	860 369	860 374
	860 370	860 375
	860 371	860 368
	860 372	

## ISTRUZIONI PER L'USO

### DATI TECNICI

Materiale:	ottone, acciaio
Superficie:	romo satinato
Tensione:	230 / 240 V
Wattaggio di lampada:	max. 60 W
Portalampada p. zoccolo:	G 9
Lampadina:	QT 14

Tipo di protezione: 

### AVVERTENZE GENERALI PER LA SICUREZZA

- Per tutti i lavori da eseguire sulla lampada (manutenzione, pulitura) eliminare la tensione dalla lampada!!
- La lampada non è adatta per locali umidi.
- Attenzione! La lampada ed il mezzo illuminante scottano quando funzionanti.
- Osservare la distanza minima indicata del mezzo illuminante da oggetti combustibili! (vedi lampada ).
- Attenzione: al fine di ridurre il rischio di surriscaldamento e incendio, non cavallottare i conduttori.
- Nessun diritto di garanzia in caso di modifiche apportate di propria iniziativa e/o di utilizzo inappropriato!

**VOLUME DELLA FORNITURA**  
1 lampada completo senza lampadina

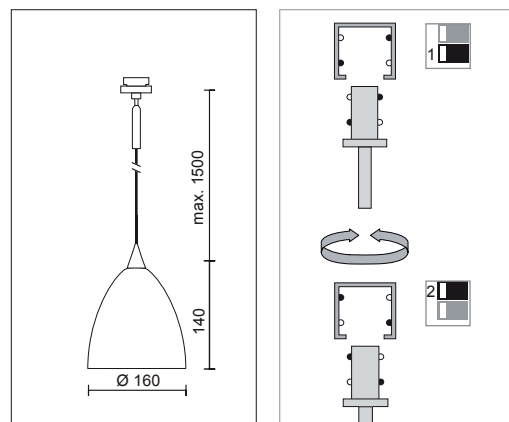
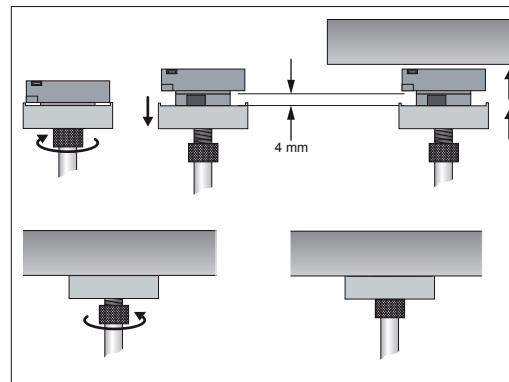
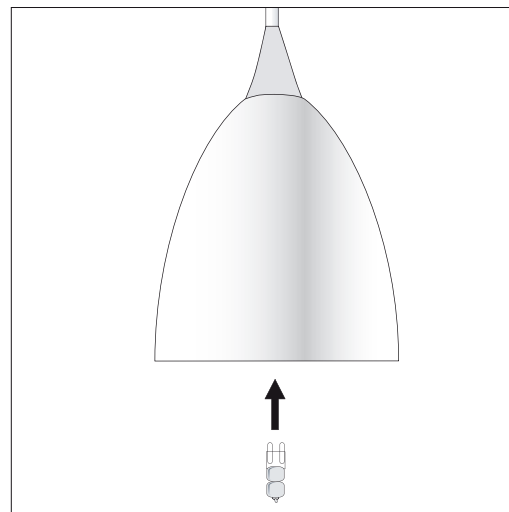

## PLANUNGSHILFE PLANNING AIDS AIDE DE PLANIFICATION AYUDA DE PLANIFICACIÓN AIUTO DI PLANIFICAZIONE

