

DUOLARE

D



EINSPESUNG D58 FLEX R LED-DLR AC
ART.-NO. 860 467



EINSPESUNG D58 FLEX-END R LED-DLR AC
ART.-NO. 860 468

GEBRAUCHSANLEITUNG

D

TECHNISCHE DATEN

Spannung: 230VAC
Leistung: max. 2 x 10A
LED: max. 10A

Schutzklasse:

Dimmbar:

! ALLGEMEINE SICHERHEITSHINWEISE !

1. Montage und Anschluß der Leuchte nur durch Fachpersonal (Elektriker).
2. Bei allen an der Leuchte durchzuführenden Arbeiten (Wartung, Reinigung) **Leuchte spannungsfrei schalten!!**
3. Leuchte ist **nicht** für Feuchträume geeignet.
4. Vorsicht! Leuchte und Leuchtmittel werden in Betrieb heiß.
5. Den angegebenen Mindestabstand der Leuchtmittel zu brennbaren Gegenständen beachten! (siehe Leuchte (P→E))
6. Keine Gegenstände über die Leuchte hängen: **Kurzschluß und Brandgefahr!**
7. Kein Garantieanspruch bei eigenmächtigen Veränderungen und oder unsachgemäßer Benutzung!



Einspeisung
Power Feed
Alimentation
Alimentación
Alimentazione
(860467)

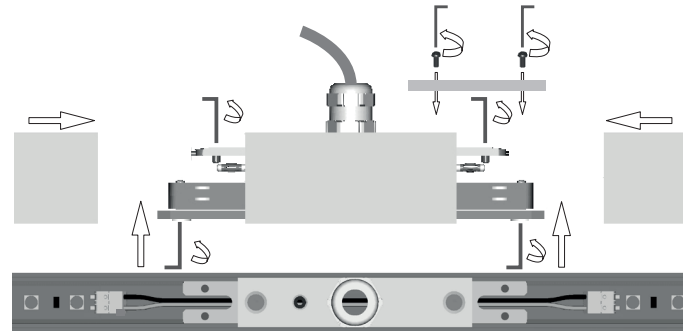

Einspeisung End
Power Feed End
Alimentation Final
Alimentación Final
Alimentazione Final
(860468)

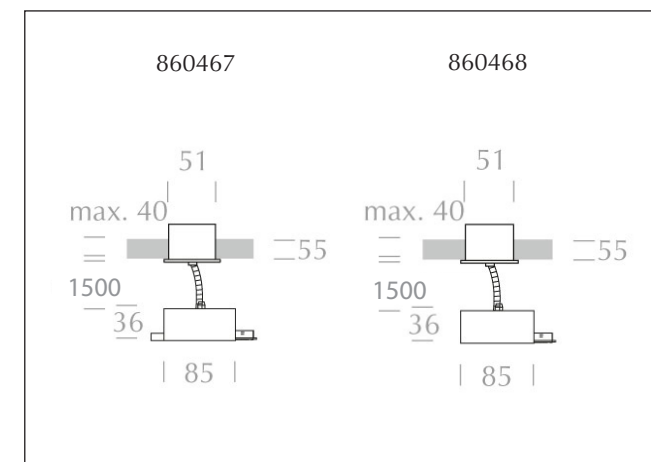
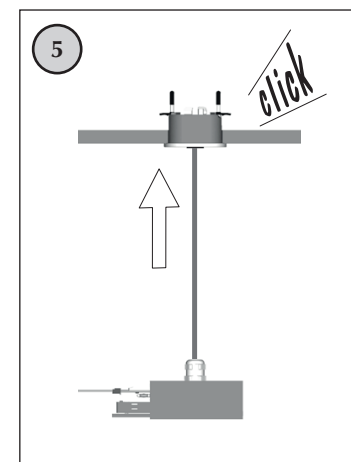
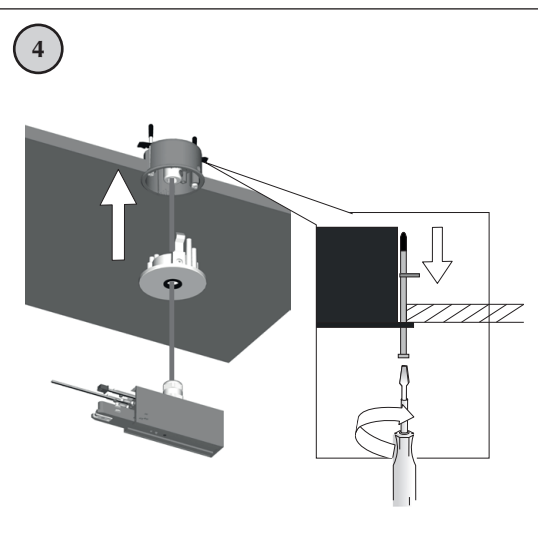
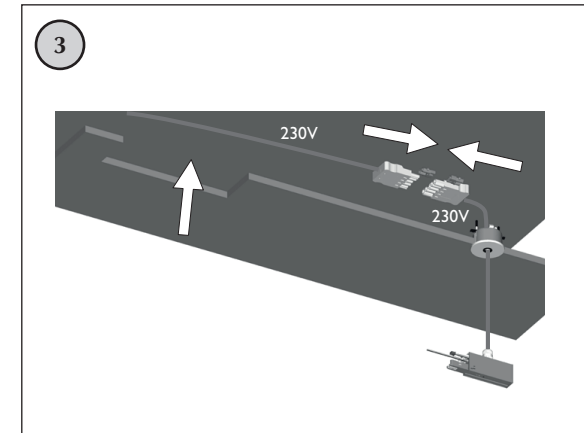
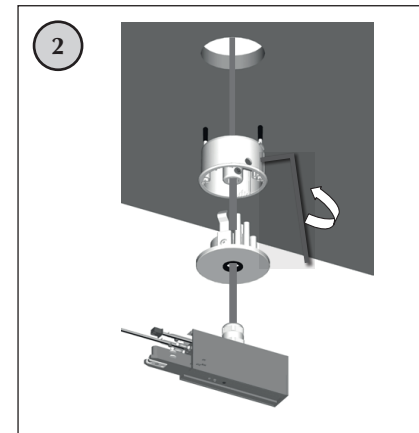
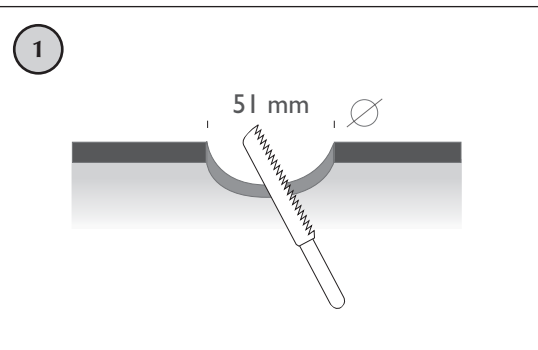
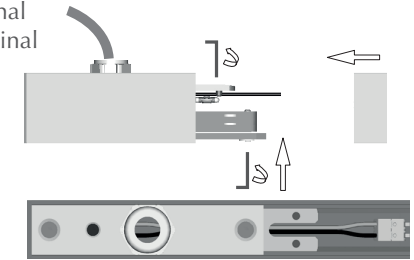

DUOLARE

GB

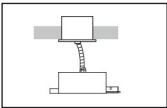
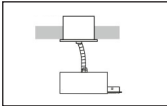
POWER FEED D58 FLEX R LED-DLR AC
ART.-NO. 860 467POWER FEED D58 FLEX-END R LED-DLR AC
ART.-NO. 860 468

INSTRUCTIONS FOR USE

GB

SPECIFICATIONS

Current:	230VAC
Load:	max. 2 x 10A
LED:	max. 10A
Protection class:	
Dimmable:	

GENERAL REMARKS ON SAFETY

1. Assembly and connection of the system only by specialist personnel (electrician).
2. For all work to be performed on the lamp (maintenance, cleaning): **Switch off power to the lamp!!**
3. Lamp **not** suitable for installation in wet rooms.
4. Take care! Lamp and illuminant become hot during operation.
5. Observe the stated minimum distance of the illuminants to flammable objects! (see lamp)
6. Do not hang objects over the lamp: **Hazard of short circuit and fire hazard!**
7. No warranty claim in case of unauthorized modifications and / or improper use!



DUOLARE

F

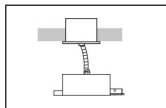
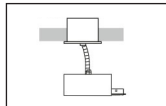
ALIMENTATION D58 FLEX R LED-DLR AC
ART.-NO. 860 467ALIMENTATION D58 FLEX-END R LED-DLR AC
ART.-NO. 860 468

MODE D'EMPLOI

F

CARACTERISTIQUES TECHNIQUES

Courant:	230VAC
Charge:	max. 2 x 10A
LED:	max. 10A
Type de protection:	
Dimmable:	

CONSIGNES DE SECURITE GENERALES

1. Le montage et le raccordement des luminaires ne doivent se faire que par du personnel spécialisé (électricien).
2. Avant d'effectuer tout travail sur le luminaire (entretien et nettoyage) **mettre le luminaire hors tension.**
3. **N'est pas approprié à être installé dans des pièces humides.**
4. **Attention!** Les luminaires et les lampes sont brûlantes lors de leur utilisation.
5. Veiller à respecter l'intervalle minimum indiqué des lampes par rapport à des objets inflammables! (voir luminaires)
6. Ne pas suspendre d'objets au-dessus des luminaires, **danger de court-circuit et d'incendie.**
7. Nous ne donnons aucune garantie lors de modifications effectuées sur le matériel ou lors d'une utilisation inadéquate.



DUOLARE

E

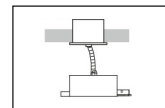
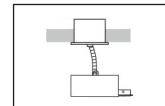
ALIMENTACIÓN D58 FLEX R LED-DLR AC
ART.-NO. 860 467ALIMENTACIÓN D58 FLEX-END R LED-DLR AC
ART.-NO. 860 468

MODO DE EMPLEO

E

ESPECIFICACIONES TÉCNICAS

Corriente:	230VAC
Potencia de lámpara:	max. 2 x 10A
LED:	max. 10A
Clase de protección:	
Regulable:	

INDICACIONES GENERALES DE SEGURIDAD

1. El montaje y la conexión de las lámparas deben ser llevados a cabo solamente por personal técnico (electricistas).
2. ¡En todos los trabajos a llevar a cabo en las lámparas (trabajos de mantenimiento y limpieza) han de mantenerse las **lámparas libre de tensión!**
3. El sistema **no** es apropiado para la instalación en locales húmedos.
4. ¡**Cuidado!** Las lámparas y las bombillas o reflectores se calientan durante el funcionamiento.
5. ¡Ha de observarse la distancia mínima indicada de las bombillas o reflectores respecto de los objetos combustibles! (véase la lámpara).
6. No colgar ningún objeto por encima del sistema: **¡peligro de cortocircuito y de incendio!**
7. ¡Se pierden las reivindicaciones de garantía al llevar modificaciones a cabo por propia cuenta y / o empleo incorrecto!



DUOLARE

I

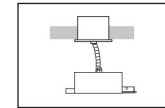
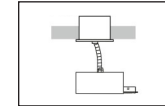
ALIMENTAZIONE D58 FLEX R LED-DLR AC
ART.-NO. 860 467ALIMENTAZIONE D58 FLEX-END R LED-DLR AC
ART.-NO. 860 468

ISTRUZIONI PER L'USO

I

DATI TECNICI

Corrente:	230VAC
Carico:	max. 2 x 10A
LED:	max. 10A
Tipo di protezione:	
Dimmerabile:	

AVVERTENZE GENERALI PER LA SICUREZZA

1. Il montaggio e il collegamento della lampada vanno effettuati esclusivamente da personale specializzato (elettricista).
2. Per tutti i lavori da eseguire sulla lampada (manutenzione, pulitura) **eliminare la tensione dalla lampada!!**
3. La lampada **non** è adatta per locali umidi.
4. **Attenzione!** La lampada ed il mezzo illuminante scottano quando funzionanti.
5. Osservare la distanza minima indicata del mezzoilluminante da oggetti combustibili! (vedi lampada)
6. Non appendere oggetti al di sopra della lampada: **pericolo di corto circuito e di incendio!**
7. Nessun diritto di garanzia in caso di modifiche apportate di propria iniziativa e/o di utilizzo inappropriato!

