



# BOOH 250 pendant lights

BOOH 250 GU10 ALL-IN

710682sw  
G10  
Dimmable  
Price €479.00 incl. VAT

**Shade Color**  
amber

**Systems**  
ALL-IN 230V track

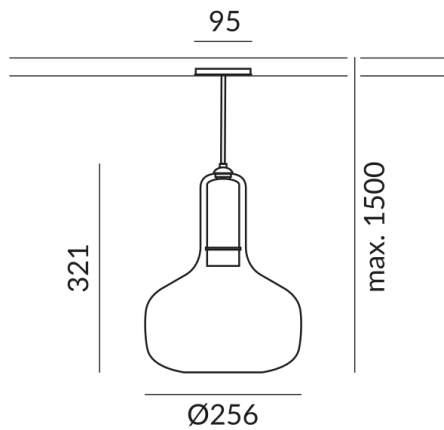

## Technical specifications

- Body color**  
painted black
- Shade color**  
amber
- Primary connection voltage**  
230 Volt
- Dimmable**  
Universal (L,C)
- Input power**  
9 Watt
- Safety class**  
2
- Ingress protection**  
IP20



---

**BRUCK GmbH & Co. KG**  
Industriestr. 22a  
44628 Herne

Tel: +49 (0)2323 - 5910  
E-Mail: [sales@bruck.de](mailto:sales@bruck.de)

<https://bruck.de>