



BOOH pendant lights

BOOH 170 GU10 ALL-IN

710680sw
G10
Dimmable
€409.00

Available, delivery time: 3-5 days

Shade Color
amber

Systems
ALL-IN 230V track

Diameter
170mm

Technical specifications

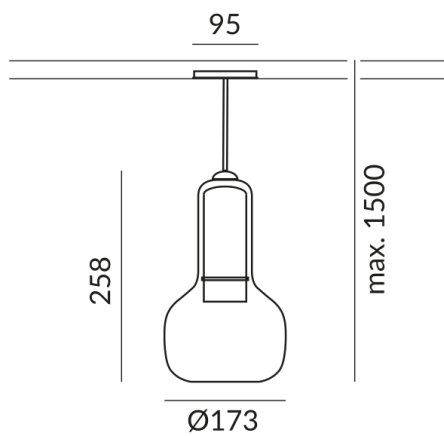

Body color
painted black

Shade color
amber

Primary connection voltage
230 Volt

Dimmable
Universal (L,C)

Input power
9 Watt

Safety class
2

Ingress protection
IP20

Weight
1.18 kg



BRUCK GmbH & Co. KG
Industriestr. 22a
44628 Herne

Tel: +49 (0)2323 - 5910
E-Mail: sales@bruck.de

<https://bruck.de>