



BOOH pendant lights

BOOH 250 GU10 S

104682sw
G10
Dimmable
€469.00

Available, delivery time: 7 days

Shade Color
amber

Systems
Single luminaires

Diameter
250mm

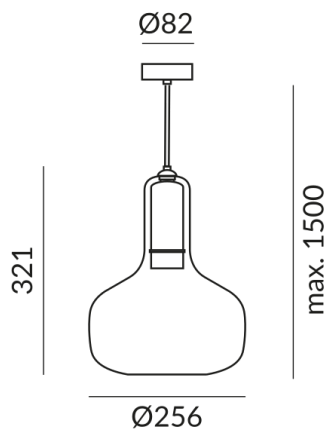

Technical specifications

Body color
painted black

Shade color
amber

Primary connection voltage
230 Volt

Dimmable
Universal (L,C)

Input power
9 Watt

Safety class
2

Ingress protection
IP20

Weight
1.63 kg



BRUCK GmbH & Co. KG
Industriestr. 22a
44628 Herne

Tel: +49 (0)2323 - 5910
E-Mail: sales@bruck.de

<https://bruck.de>